

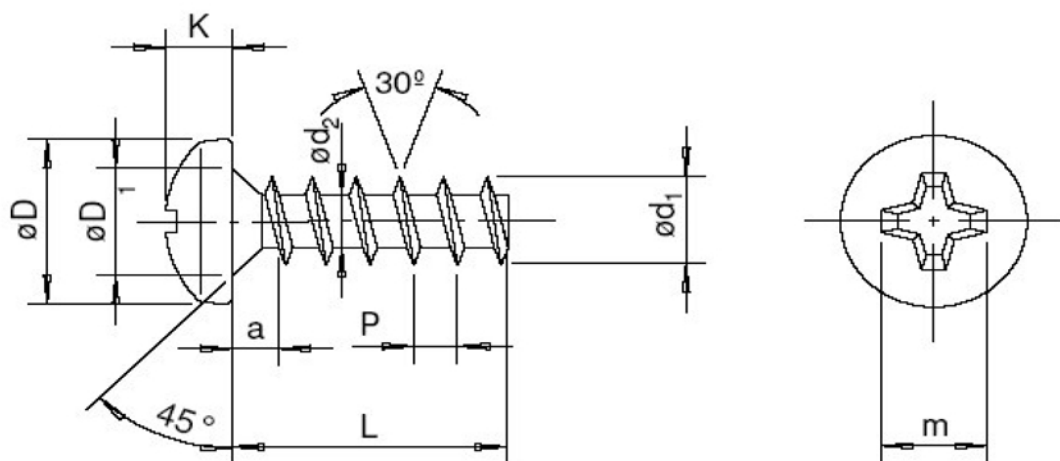

IRPAL PARAFUSOS

Parafuso Plastic Painela Fenda Philips



DIAM. NOMINAL		3.00	3.50	4.00	4.50	5.00	6.00
Passo		1.35	1.60	1.80	2.00	2.20	2.60
D	min.	5.50	6.54	7.14	7.84	9.14	10.37
	max.	6.00	6.90	7.50	8.20	9.50	10.80
D1	min.	2.90	3.60	3.90	4.40	5.40	6.20
	max.	3.00	3.70	4.00	4.50	5.50	6.30
K	min.	2.10	2.35	2.55	2.75	3.25	3.65
	max.	2.34	2.60	2.80	3.05	3.55	3.95
N° da Chave		2					
m	Ref.	3.80	4.20	4.40	4.60	5.80	5.80
P	min.	0.90	1.40	1.63	1.80	3.40	3.40
	max.	1.60	2.03	2.26	2.45	4.00	4.00
Ch	Ref.	Ø3,5 x 45°	Ø4,0 x 45°	Ø4,5 x 45°	Ø5,0 x 45°	Ø5,5 x 45°	Ø6,5 x 45°
L	min.	10.00	12.00	12.00	16.00	25.00	25.00
	max.	30.00	40.00	50.00	60.00	60.00	60.00

COMPRIMENTO DE ESTAMPAGEM

L até 12mm - Nominal -0,8 / -1,0 / Acima de 12mm - Nominal -1,80 / -2,00

Comprimento L (mm)	PESO APROXIMADO DE 1000 PEÇAS EM KILOS					
	10.00	0.601	0.880			
12.00	0.670	0.910	1.020			
14.00	0.735	0.920	1.120			
16.00	0.770	0.930	1.230	1.600		
20.00	0.880	1.120	1.430	1.880		
22.00	0.900	1.180	1.460	1.940		
25.00	1.000	1.310	1.750	2.140	3.000	4.560
30.00		1.520	1.990	2.480	3.300	5.100
35.00		1.700	2.250	2.700	3.750	5.400
40.00		1.940	2.510	3.030	4.050	6.000
45.00			2.710	3.500	4.350	6.750
50.00			2.910	3.700	4.800	7.360
60.00			3.150	4.310	5.420	8.500