

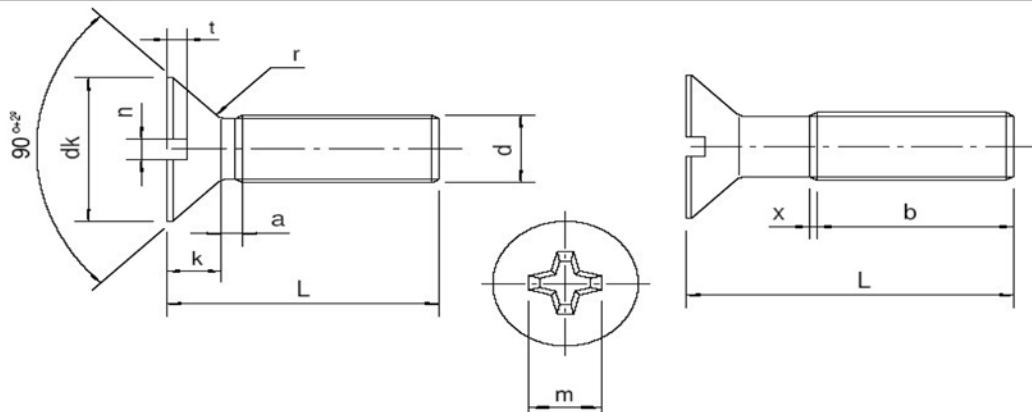

IRPAL PARAFUSOS

Parafuso Maquina Cabeça Chata - Rosca ww



DIAM. NOMINAL		3/32"	1/8"	9/64"	5/32"	3/16"	1/4"	5/16"	3/8"
F.P.P		48	40	32	32	24	20	18	16
dk	min.	4.00	5.30	6.50	6.80	8.80	10.40	13.50	15.30
	max.	4.40	5.50	6.70	7.00	9.00	11.00	14.00	16.00
K	min.	1.00	1.40	1.60	1.70	2.10	2.60	3.20	3.50
	max.	1.20	1.50	1.80	1.90	2.30	2.80	3.40	3.70
n	min.	0.60	0.90	1.00	1.10	1.30	1.60	1.80	2.00
	max.	0.80	1.10	1.20	1.30	1.50	1.90	2.10	2.30
t	min.	0.50	0.70	0.80	1.00	1.20	1.40	1.60	2.00
	max.	0.70	0.90	1.00	1.20	1.40	1.70	2.00	2.40
r	max.	0.60	0.90	1.10	1.30	1.50	1.80	2.00	2.20
Nro da Chave		1		2		3	4		
m	Ref.	2.40	3.00	3.90	4.20	4.60	6.70	9.60	10.10
p	min.	1.01	1.40	1.82	2.03	2.10	2.94	4.93	5.41
	max.	1.42	1.70	2.12	2.61	2.60	3.53	5.53	6.02
b	min.	25	25	25	38	38	38	38	38
X	max.	1.00	1.10	1.25	1.50	1.75	2.00	2.50	3.20
L	min.	1/4"	1/4"	1/4"	1/4"	1/4"	5/16"	3/8"	
	max.	1.1/2"	2"	2"	2.1/2"	3"	3"	4"	
Comprimento		PESO APROXIMADO DE 1000 PEÇAS EM KILOS							
L (mm)									
1/4"									
5/16"									
3/8"									
1/2"									
5/8"									
3/4"									
7/8"									
1"									
1.1/4"									
1.1/2"									
1.3/4"									
2"									
2.1/4"									
2.1/2"									
3"									